



TYPHOON INTAKE SYSTEMS

INSTALLATION INSTRUCTIONS

**69-2020
MINI
2000-06 Cooper
L4-1.6L
2000-06 One
L4-1.6L**

NOTE: C.A.R.B. E.O. # D-269-30 APPLIES TO 2002-2004 MINI COOPER MODELS ONLY.

TOOLS NEEDED:

6" Extension
8mm Socket
12mm Socket
3mm Allen Wrench
4mm Allen Wrench
Flat Blade Screwdriver
Needle Nose Pliers
Pliers
Ratchet
Side Cutters

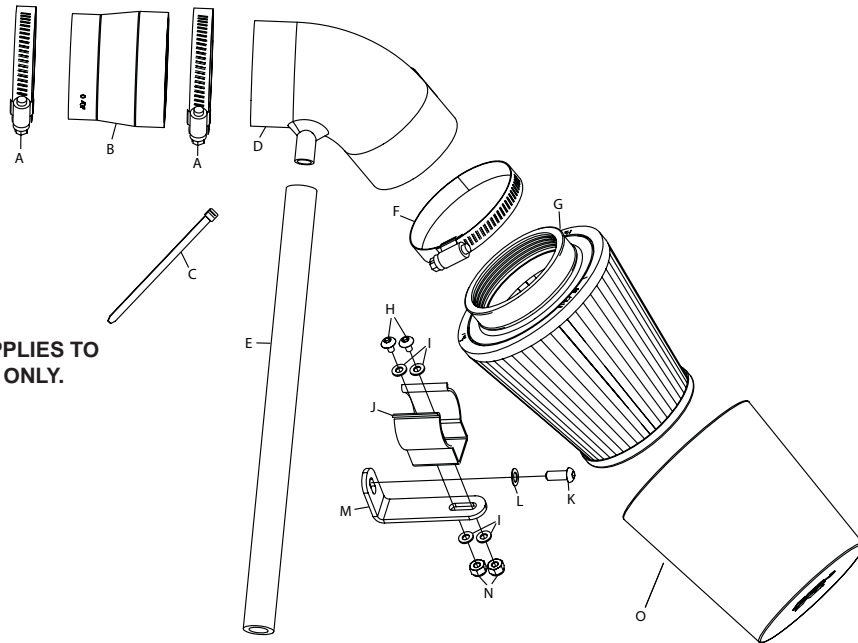

PARTS LIST:

Description	Qty.	Part #
A Hose Clamp, #44	2	08560
B Silicone Hose, Black	1	084016
C Cable Tie	1	21589
D Typhoon® Intake Tube	1	27107
E Silicone Hose, 1/2"ID x 12"L	1	087031
F Hose Clamp, #44	1	08577
G Air Filter	1	RC-9350
H 5mm Button Head Screw, 12mm L	2	07734
I 5mm Flat Washer	4	08212
J Spring Holder, Black	1	08308
K 6mm Button Head Screw, 12mm L	1	07794
L 6mm Wave Washer	1	08277
M "L" Bracket	1	070742
N 5mm Nylock Hex Nut	2	07507
O Drycharger®	1	RC-9350DK

NOTE: FAILURE TO FOLLOW INSTALLATION INSTRUCTIONS AND NOT USING THE PROVIDED HARDWARE MAY DAMAGE THE INTAKE TUBE, THROTTLE BODY AND ENGINE.

TO START:

1. Turn off the ignition and disconnect the negative battery cable.

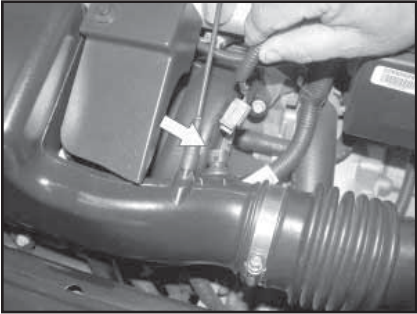

2. Remove the stock crank case vent hose from the cam cover as shown.

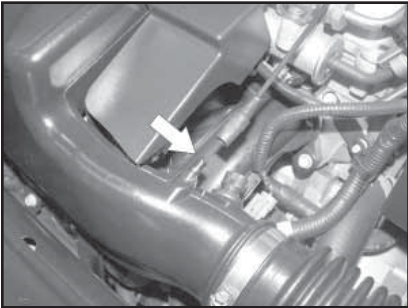

3. Using a pair of side cutters cut the factory hose clamps on the stock intake tube at the throttle body and at the air cleaner assembly as shown.

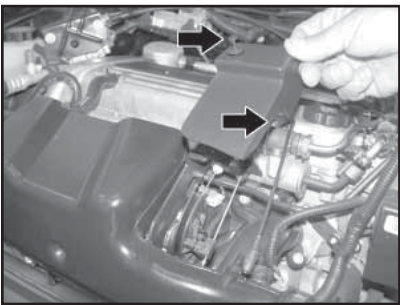

4. Remove the stock intake tube as shown.

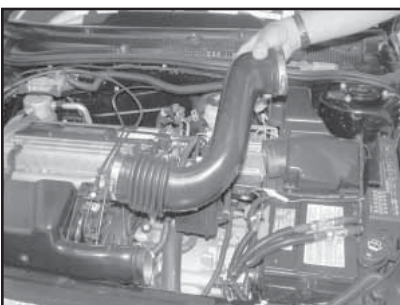

5. Remove the harness multi plug from the side of the air cleaner assembly.

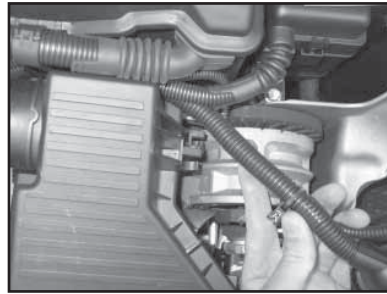

6. Using a pair of needle nose pliers unclip the electrical harness from the side of the air box assembly as shown.

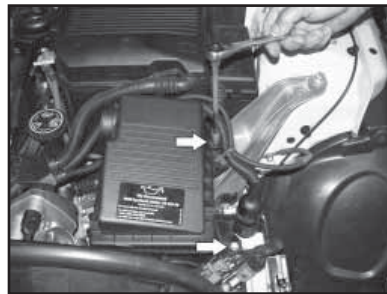

7. Models between April 2001-2004: Remove the two bolts that secure the air cleaner assembly as shown.

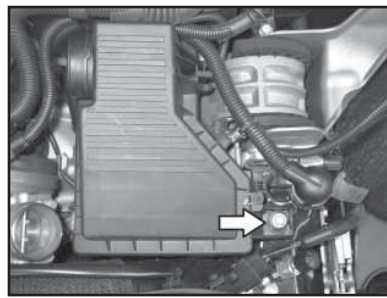

8. Models from 2005: Remove the single bolt that secure the air cleaner assembly as shown.

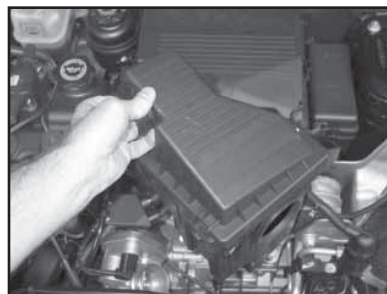

9. Remove the air cleaner assembly from the vehicle as shown.

NOTE: Pull firmly upwards while moving the assembly in a side to side motion to remove.

NOTE: K&N® recommends that customers do not discard factory air intake.

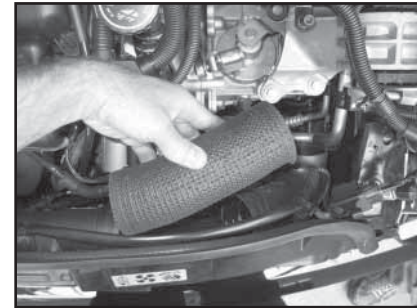

10. Remove the foam feed pipe from between the intake scoop & resonator box as shown.

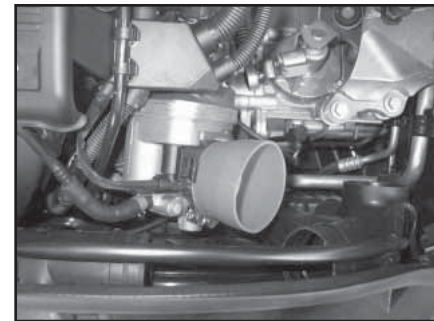

11. Secure the silicone stepped hose & hose clamps onto the throttle body as shown.

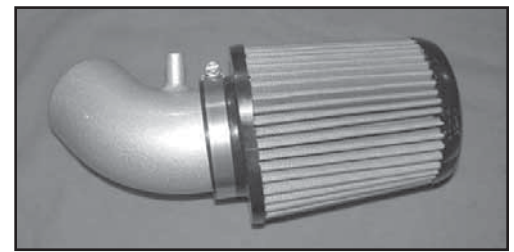

12. Install the air filter onto the Typhoon® intake tube as shown.

NOTE: Before installing the air filter, inspect the inside of the tube for any debris, then clean the inside out with water and a towel. Inspect the tube one more time before proceeding to the next step.

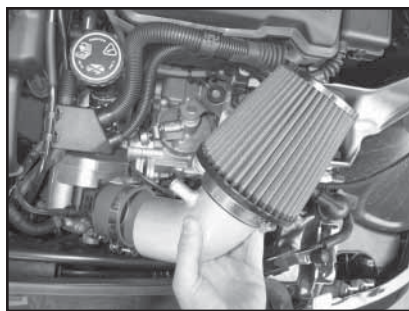

13. Slide the intake tube assembly into the silicone stepped hose & adjust for best fit & clearance as shown.

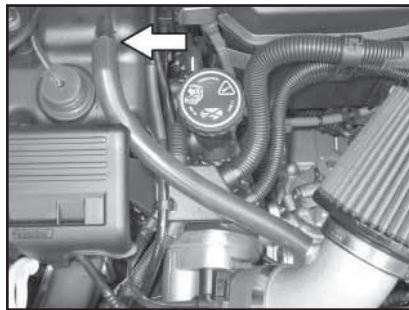

14. Install the provided silicone hose onto the crank case vent on the cam cover, then, attach the other end onto the vent on the intake tube as shown.



15. Assemble the two provided brackets using the provided hardware as shown.

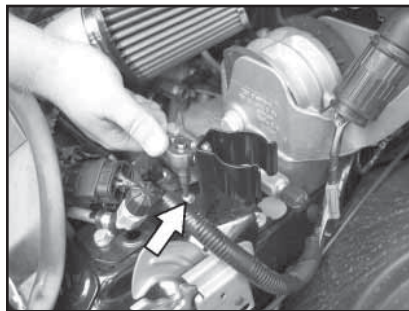

16. Install the bracket assembly to the original air cleaner mounting point using the provided hardware as shown.

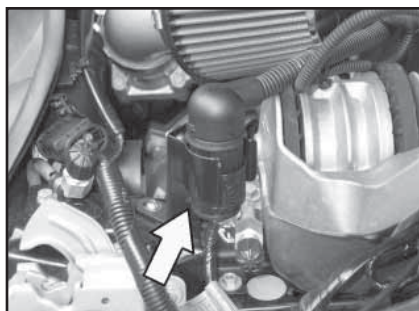

17. Slide the harness multi plug into the bracket as shown.



18. Secure the harness away from the air filter using a provided plastic tie as shown.

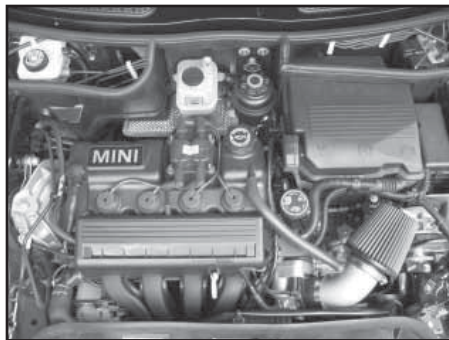

19. Reconnect the negative battery cable. Double check to make sure everything is tight & properly positioned before starting the vehicle.

20. The C.A.R.B. exemption sticker, (attached), must be visible under the hood, so that an emissions inspector can see it when the vehicle is required to be tested for emissions. California requires testing every two years, other states may vary.

20. It will be necessary for all K&N® Intake Kits to be checked periodically for realignment, clearance and tightening of all connections. Failure to follow the above instructions or proper maintenance may void warranty.

ROAD TESTING:

1. Start the engine with the transmission in neutral or park, and the parking brake engaged. Listen for air leaks or odd noises. For air leaks secure hoses and connections. For odd noises, find cause and repair before proceeding. This kit will function identically to the factory system except for being louder and much more responsive.
2. Test drive the vehicle. Listen for odd noises or rattles and fix as necessary.
3. If road test is fine, you can now enjoy the added power and performance from your kit.
4. K&N® suggests checking the air filter element periodically for excessive dirt build-up. When the element becomes covered in dirt (or once a year), service it according to the instructions on the Recharger® service kit, part number 99-5000 or 99-5050.